



**avasco
solar**



assembly instructions





SolarSpeed 3.0 **east-west landscape**

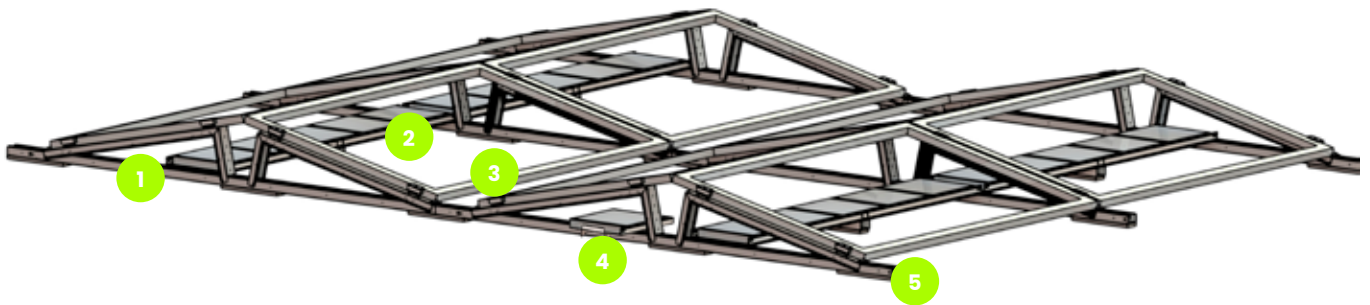

SolarSpeed components









standard components

- 
1 basic unit:
semi-assembled triangles
+ rail + protective rubbers*
- 
2 set of L-profiles
+ centre piece
- 
3 clamps + M8 bolts
- 
4 ballast support
- 
5 end rubber*

* For PVC roofs use rubber with aluminium underlay.

additional components

- 
concrete footing (12kg)
+ hammer plug
- 
PP footing
- 
ridge connection
- 
C-rail end
reinforcement
- 
omega bracket
- 
anchor profile



required assembly tools



chalk line



hammer



screwdriver



socket 3/8"
socket SW8



electric tool



hex 6.0



torque wrench
range 15-30Nm



Avasco Solar spacer

prior to assembly

Ensure that the roof surface where the frame will be mounted on is clean, dry, and flat. Contaminants such as gravel, sand or pebbles can cause roof damage or installation instability.

correct assembly of sheet metal screws

Prescribed compression EPDM washer: 25% of original thickness.
Use tools with depth control!

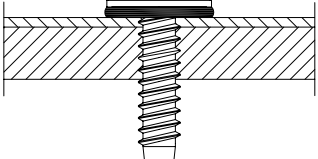
Correctly screwed on

Tightened too loosely

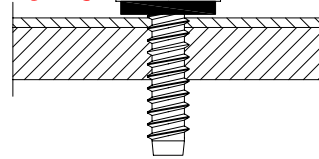
Tightened too far
(seal damaged)

Tightened too angled
(seal damaged)

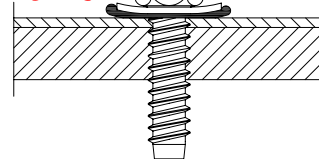
Choosing the correct installation tool is essential for the fastener to drill and tap as designed. The selected screw gun must have a variable trigger to deliver a controlled speed between 1700 and 2000 rpm without end loading. It should provide torque up to 30Nm with a clutch mechanism to prevent excessive torque and speed, which can cause damage or 'stripping out' the fastener. Socket 3/8" must be used with sheet metal screws, socket SW8 with self-drilling screws.

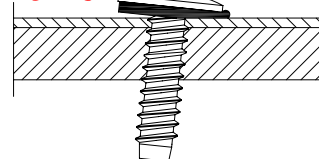

step 1: mounting basic units

step 1.1: from semi-assembled to assembled basic units

required components:



basic unit
(semi-assembled)



C-rail end reinforcement
(optional)



sheet metal screws
(Ø6.5x19mm)

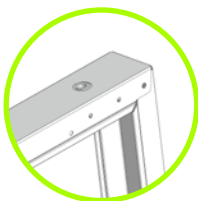

Lift the semi-assembled basic unit and bend it until the holes in the top of the triangle are aligned. Squeeze the sides of the short leg to fit inside the longer leg while bending.



Secure the ends of each assembly triangle to the rail using 2 sheet metal screws (Ø6.5x19mm).



Bend the panel stop to a 90° angle using a screwdriver.





step 1.2: securing top of triangles

Secure the top of each assembly triangle using 2 sheet metal screws (Ø6.5x19mm).

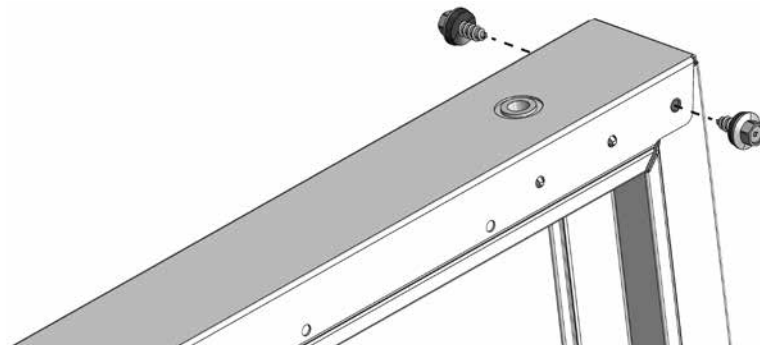

step 1.3: connecting the basic units

- Place the basic units on a flat and stable roof surface.
- Connect the basic units by sliding the tapered rail end into the rail of the previous basic unit until you hear a clicking sound.

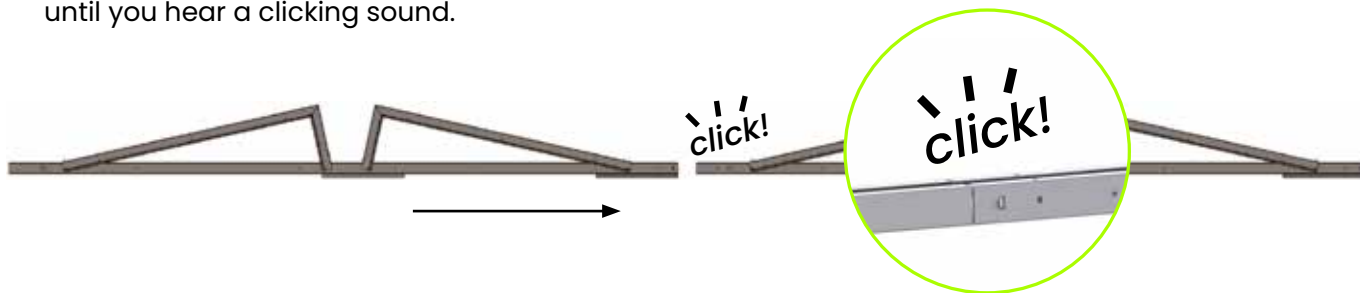

step 1.4: (optional) installing C-rail end reinforcement

Install the C-rail end reinforcement by sliding it between the assembly triangle and the rail. Secure it with 2 sheet metal screws (Ø6.5x19mm).

An indication of the locations can be calculated with our free online calculator: solarspeed.avasco.be.

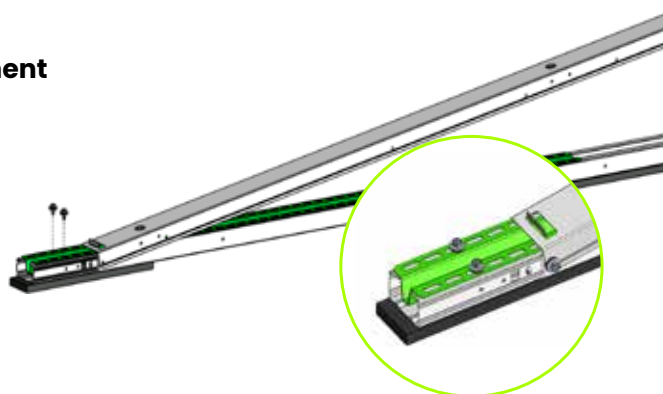



step 1.5: (optional) installing single East or West facing module.

required components:



EWE rail



triangle



sheet metal screws
(Ø6.5x19mm)

The triangle is installed in the first or the last hole of the rail as shown in the image below to create an East or West facing basic unit.

Secure the East or West facing basic unit in a similar way as described in the previous steps.

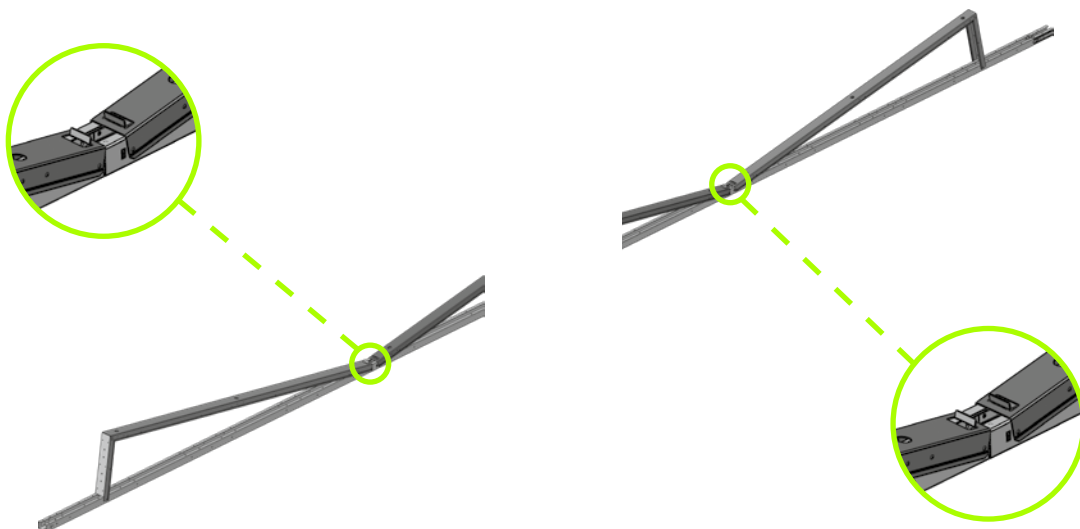



step 2: aligning the rows

step 2.1: plotting the rows

required assembly tools:



spacer



chalk line



Tip!

Make a horizontal and vertical mark on the roof using a chalk line. When setting out the markers, respect the minimum edge zones (see general notes).



Align the rows according to plan, taking into account the length of the panels.
To easily determine the distance between the basic units, you can use the spacer.

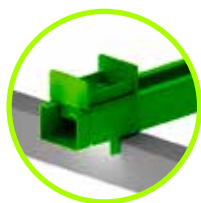

Set the length of the panel on the spacer.

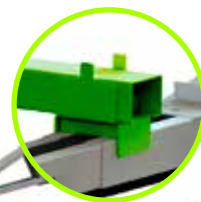
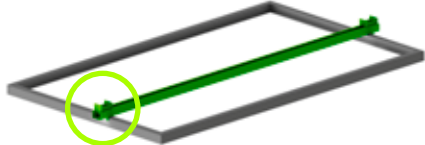

Turn the spacer 180° and align the rows.

step 2.2: providing dilatations (thermal breaks)

In the north-south direction, also referred to as the ALU direction, a dilatation must be provided at least once every 26 metres. The distance between these 2 basic units must be at least 300mm to allow the use of ballast supports.

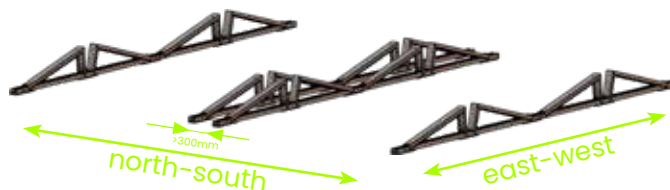

In the east-west direction, also referred to as the steel direction, a dilatation must be provided at least once every 30 metres. This is done by inserting only 75% of the tapered rail end into the rail of the previous basic unit.



Caution! If you hear a clicking sound, the rail has been inserted too far. You must disconnect the rails.



step 3: attaching footing system

An indication of the required footing systems and ballast, their locations and the method of footing and ballasting can be calculated with our free online calculator: solarspeed.avasco.be.

Several options are possible:

- Go to step 3.1 for rubbers
- Go to step 3.2 for PP footings
- Go to step 3.3 for concrete footings
- Go to step 3.4 for mounting on metal substructure
- Go to step 3.5 for mounting with roof anchors

step 3.1: attaching end rubber at the end of the rail

required components:



end rubber



plastic plugs



Push 2 plugs into the holes of the rubbers



Attach the rubbers to the rail by pushing the plugs into the provided holes.

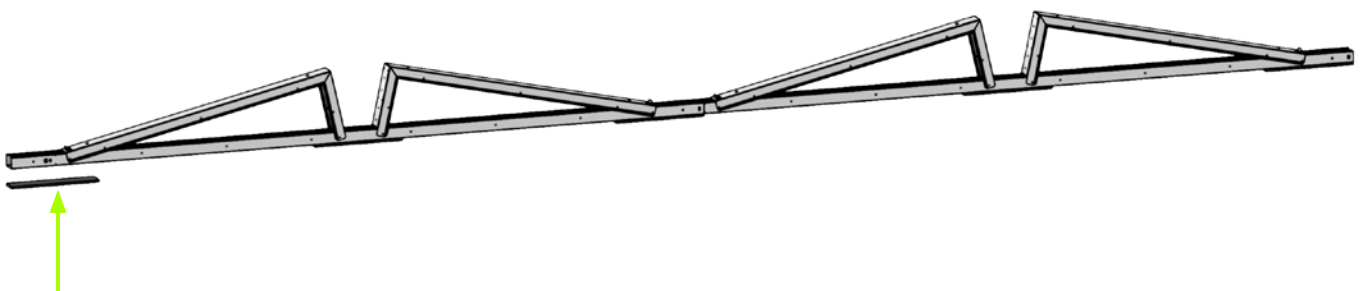

Go to step 4.



step 3.2: installing PP footing

required components:



PP footing



sheet metal screws (Ø6.5x19mm)



PP footings are placed under the full length of the connected basic units. This means that a footing is always placed at the beginning and end of the connected basic units, as well as centrally beneath the basic unit.

The PP footing can be attached to the basic unit by securing it with 2 sheet metal screws in the provided holes in the rail of the basic unit.

The PP footings are available with or without pre-installed rubbers.

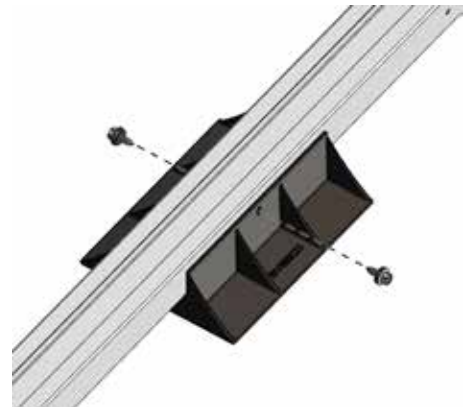

Go to step 4.



step 3.3: installing concrete footing

required components:



concrete footing + hammer plug



rubber protection

A footing is placed at the beginning and the end of the connected basic units. A rubber is always placed under the concrete footings to protect the roof surface. At least 5mm of rubber must be visible on each side of the concrete footing.

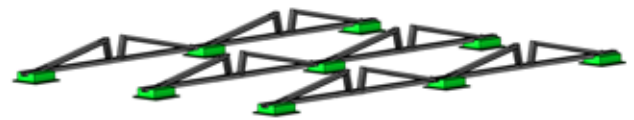

In case of green or pebble roofs, remove the plants or pebbles at the places where the concrete footings need to be installed.

Caution! Depending on the required ballast, it may also be necessary to place an extra concrete footing in the centre of the basic unit.

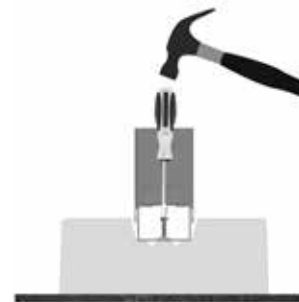

Once the concrete footings are correctly positioned, the connected basic units can be attached to them. This is done with hammer plugs HPS-1 R 8/10x40.

The hammer plug is inserted into the provided holes and hammered down. Use a screwdriver as an extension to prevent damage to the basic unit.

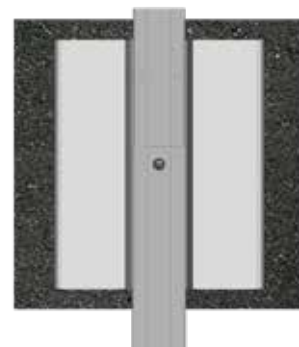

Go to step 4.



step 3.4: installing on metal substructure

required components:

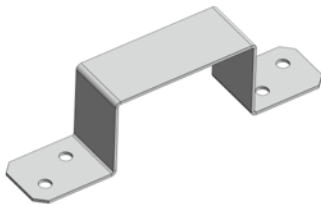

omega bracket



self-drilling screws
(Ø5.5x25mm)

SolarSpeed can be installed on metal substructure e.g. steeldeck, aluminium or steel profiles, ... This can be done with an omega bracket and self-drilling screws, see specific metal substructure assembly instructions.

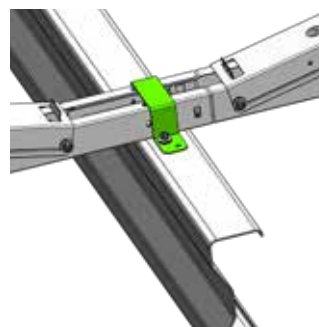
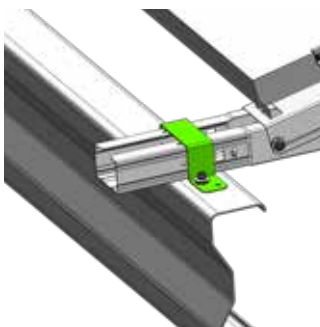
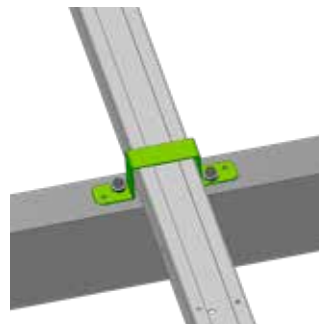
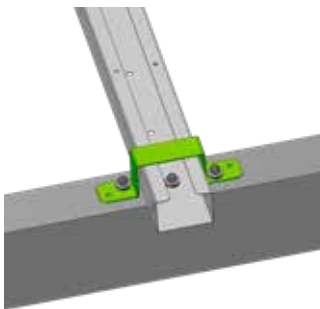

Go to step 4.



step 3.5: installing on roof anchors

required components:

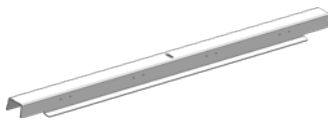

anchor profile



washer
(provided by installer)



nut
(provided by installer)



Position the basic units so that the pre-installed roof anchor is precisely centered between the two C-rails. Secure the anchor profile over the roof anchor, fastening it with a washer and nut according to the roof anchor manufacturer's installation manual.

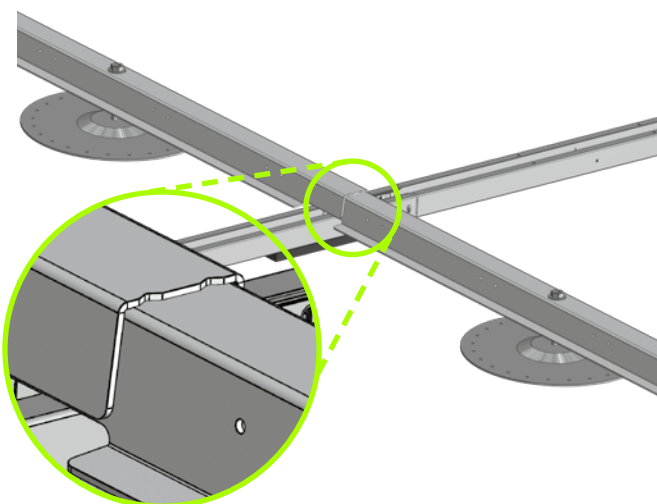

If two roof anchors are present on each side of the C-rail, the roof anchor profiles can be stacked. The widest side of the profile is identified by two indents.



step 4: placing the ballast

An indication of the required footing systems and ballast, their locations and the method of footing and ballasting can be calculated with our free online calculator: solarspeed.avasco.be.

If the ballast report says to place an L-profile set without any ballast, you must still install at least one L-profile for mechanical and equipotential connection. You do not need to install center pieces beneath L-profiles without ballast.

step 4.1: providing ballast with ballast support

required components:



ballast support



ballast tile
(provided by installer)

On the inside of the installation, the ballast can be placed on ballast supports. These can simply be placed over the rails.

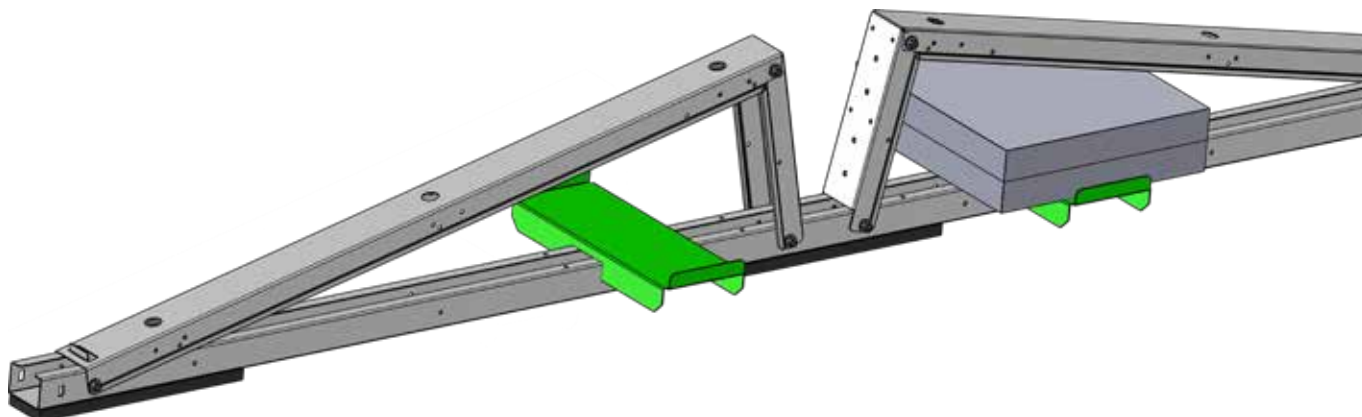



step 4.2: providing ballast with L-profiles

required components:



set of L-profiles
+ centre piece



sheet metal screws
(Ø6.5x19mm)



ballast tile
(provided by installer)

On the outer side of the installation ballast is always placed on sets of L-profiles.

The sets of L-profiles must be fixed with 4 sheet metal screws (Ø6.5x19mm) in the pre-drilled holes of the rails of the basic units (together with the optional C-rail end reinforcement).

Each optional C-rail end reinforcement must always be fixed with 4 sheet metal screws (Ø6.5x19mm) together with the L-profiles.

The centre piece must be placed in the centre of the L-profiles set where it can be assembled with 2 sheet metal screws (Ø6.5x19mm) in the pre-drilled holes.

For a set-up on PP footings the centre piece must also be placed on a PP footing.

For a set-up on concrete footings a higher centre piece is provided.

On the inner side of the installation sets of L-profiles are used when not enough ballast can be placed on ballast supports.

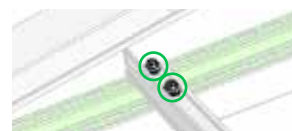
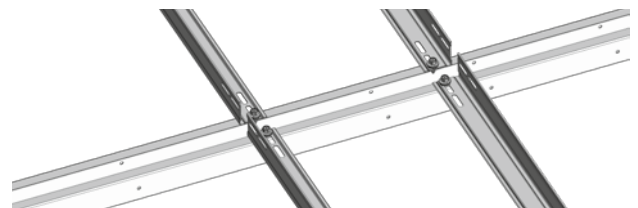



step 5: (optional) installing backplates on the East or West facing module.

required components:

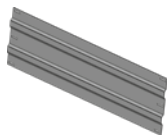

backplate



sheet metal screws
(Ø6.5x19mm)

Secure the backplates with 4 sheet metal screws (Ø6.5x19mm) on each East or West facing basic unit.

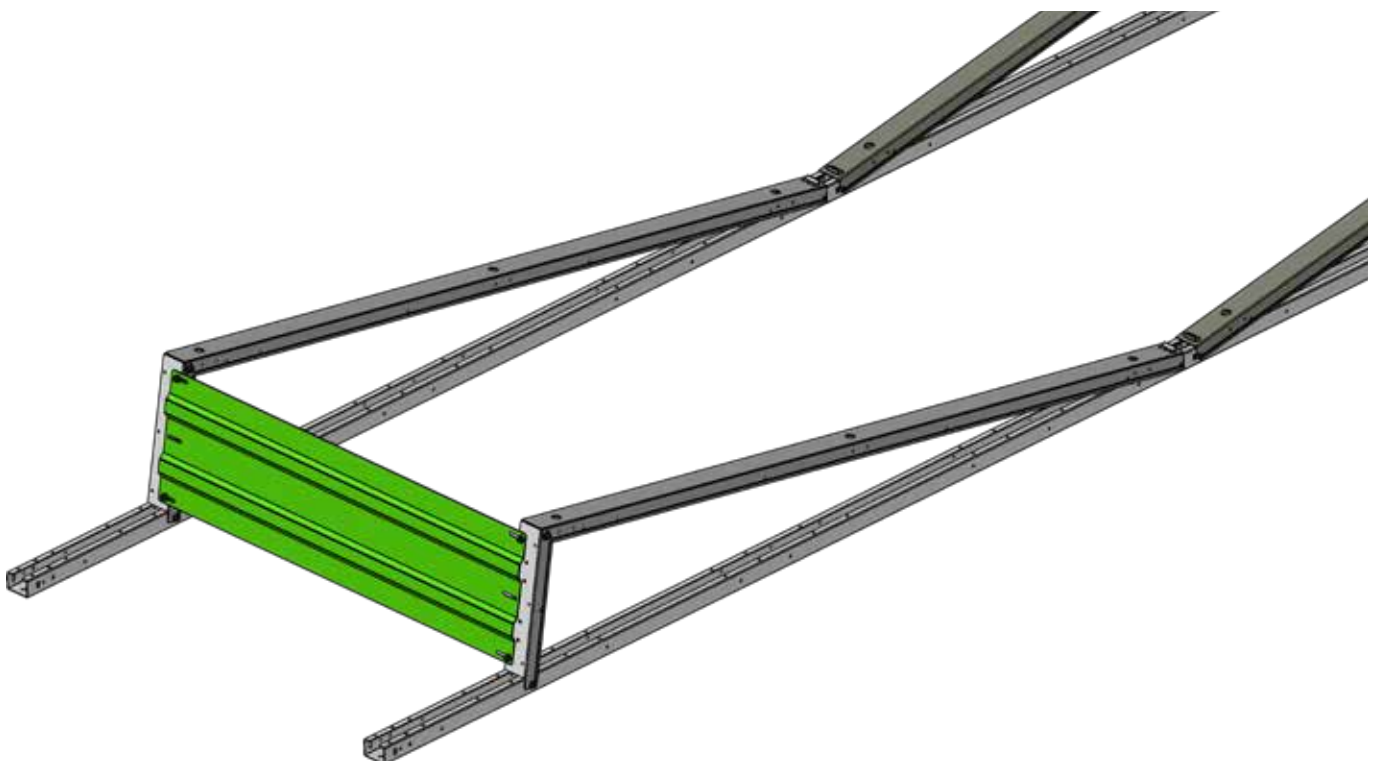



step 6: installing ridge connection

required components:

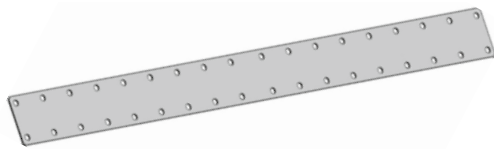

ridge connection



self-drilling screws
($\text{\O}5.5 \times 25\text{mm}$)

step 6.1: transverse ridge connections

In the transverse direction, one ridge connection is placed on every basic unit. These are attached on top of both rails. The ridge connection will bend to the appropriate slope when attached to the basic units. Use 4 self-drilling screws ($\text{\O}5.5 \times 25\text{mm}$) per rail.

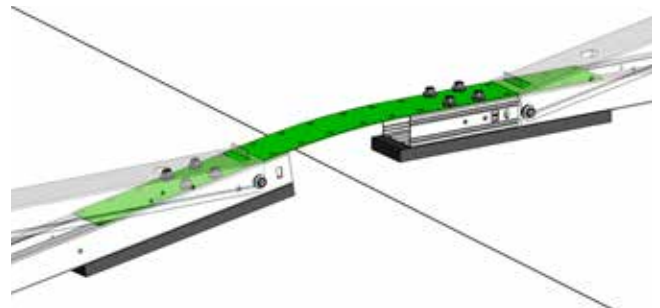

step 6.2: longitudinal ridge connections

In the longitudinal direction, one ridge connection is placed on every basic unit. These are attached on top of both rails. The ridge connection will bend to the appropriate slope when attached to the basic units. Use 4 self-drilling screws ($\text{\O}5.5 \times 25\text{mm}$) per rail.





step 7: ensuring earthing and equipotential bonding

Since the rows are electrically and mechanically interconnected, no additional connections are required between the different basic units for proper grounding.

However, the individual fields must be connected to each other with an earthing wire. This wire can be attached to the basic unit using a sheet metal screw. Ensure you use cable shoes that are not made of uncoated copper or stainless steel.

Finally, connect the SolarSpeed to the building's earthing wire.

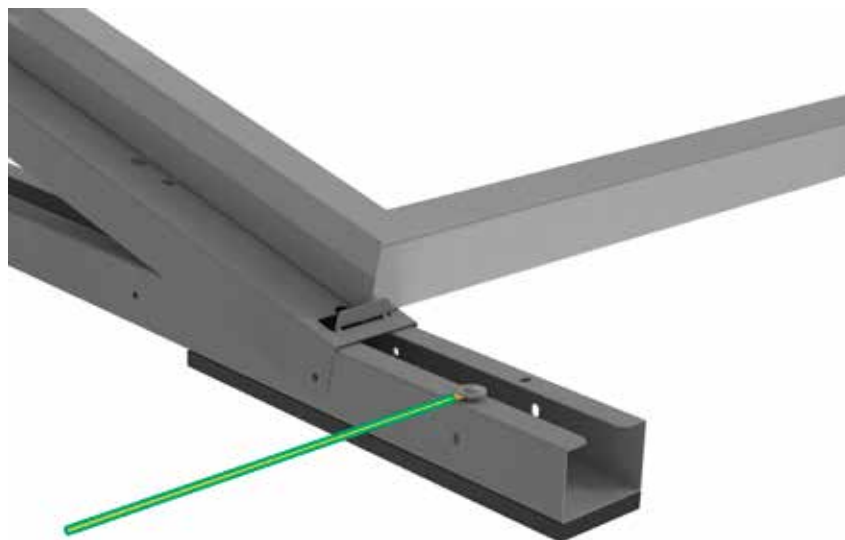



step 8: installing the modules

required components:



middle and end clamps



M8x55/55 bolt



solar panel
(provided by installer)

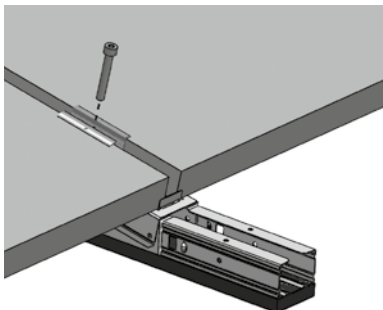

Fix the clamps into the 2 screw thread provided in the assembly triangles with the M8 bolts. Screw the 2 bolts hand tight.

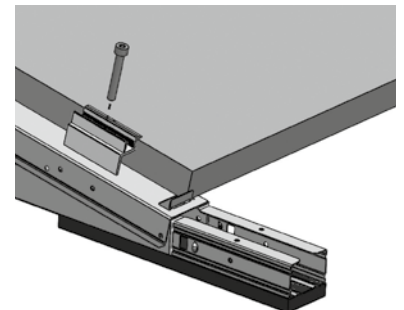

After the complete solar module array has been assembled, tighten the 2 bolts with minimum 19Nm and maximum 25Nm.
(see general notes)

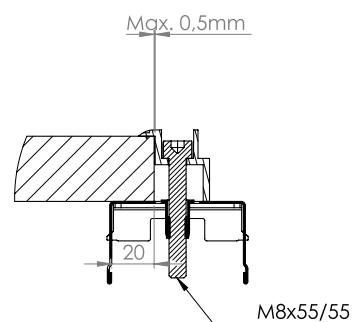
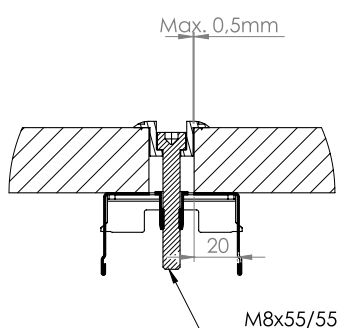



general notes

- The installer should always check whether the rubber protection is sufficient when installing on soft or semi-soft surfaces. The installer should also check the compatibility of the rubber protection with the roof surface.
- Only use the clamps approved and/or recommended by the module manufacturer. Always tighten the clamping bolt with the correct torque: Minimum 19Nm is required, maximum 25Nm is allowed. A loss of torque is to be expected: At least 13Nm must be measured during inspection after installing.
- In the following situations/circumstances, the mounting frames of **Avasco Solar plc** are not suitable, unless written confirmation is provided for a specific project:
 - PVC or TPO roofs with pitches $> 3^\circ$
 - Bitumen or EPDM roofs with pitches $> 5^\circ$
 - Places where buildings or other objects can cause a wind tunnel effect or increased wind speeds.
 - Installations closer than 2 km as the crow flies from the coastline.
 - In an aggressive environment: All materials must be in stainless steel with the correct specifications to be determined on the basis of the aggressive substances.
 - In a saline environment: Execution in anodised aluminium or stainless steel.
- Polluted roof surfaces can lead to a lower friction coefficient over time, which means that more ballast or (extra) mechanical connections must be provided to prevent sliding.
- Edge zone: The installer must always keep the minimum edge zone free as described in the applicable standard(s). An example of such a standard is the NEN7250, but this is not exhaustive.
- Installers must always provide sufficient ballast depending on the situation. In case of doubt, please contact a specialised consultancy/engineering bureau.
- It is the installer's responsibility to check if the panels can be clamped in the manner (on the short or long side, position of the clamps, etc.) as provided in this manual. If this is not the case, **Avasco Solar plc** can in no way be held responsible for any damage, in whatever form.
- **Avasco Solar plc** can never be held liable if materials are used for assembly that are not supplied by **Avasco Solar plc**.
- The warranty conditions with regard to the assembly frames of **Avasco Solar plc** are available upon request. Failure to strictly follow the assembly instructions will void all warranty.
- The installer is responsible for the use of the necessary PPE.
- **Avasco Solar plc** reserves the right to change the assembly instructions at any time. It is the installer's responsibility to always follow the latest version, which is the only valid one. This is available at all times on www.avasco-solar.be or can be obtained upon request.



**avasco
solar**



100% made in Belgium

SolarSpeed is manufactured from A to Z at our production site in Ypres. As a result, we are always in control of the quality of our products, throughout the entire production process. This local production under our own management also ensures that we can respond to market demands in an extremely flexible way. The standards that are applied at all times are those of our quality management system, ISO 9001.



on-site delivery

We always have a large number of mounting frames in stock in our warehouse. This allows us to continue to guarantee short delivery times, especially for your industrial projects. We deliver the materials directly to the site in Europe (intercontinental on demand).



Avasco Solar plc
Rodenbachstraat 53
8908 Vlamertinge - Belgium
T +32 (0)57 27 15 00
VAT BE 0721.474.320
info@avasco-solar.be
www.avasco-solar.be

**solar
mounting
frames**